

# 320P HL

## GLIDERAIL



### KEY FEATURES

- Independent Front & Rear Controls
- Automatic Down Pressure Relief on Rear Rail Gear
- Front Oscillating Hi-Rail Axle
- Bolt-on Design
- Full Function of Loaders Arms when Hi-Rail is Engaged
- Utilizes Existing OEM Stabilizers
- Available Models: 320P, 320P HL, & 310G (No DEF)
- JDLink Telematics
- 500-Hr Engine Service Intervals
- Serviceable by the Nationwide John Deere Dealer Network

### ACCESSORIES AND OPTIONS

Tool Circuit & Reel  
Tiltrotator Coupler  
Rail Forks  
Hydraulic Cribbing Thumb  
Hammer  
Plate Compactor  
Vision360  
Tie Grapple  
Scrap Cart

### STANDARD SPECIFICATIONS

JD PowerTech EWL 4.5L Engine  
EPA Final Tier 4/EU State IV  
86 kW (115 Hp) @ 1900 RPM  
5-Speed PowerShift™ Transmission  
MFWD w/ Limited Open Differentials  
Extendible Heavy Lift Dipperstick  
Loader Hydraulic Coupler

### RCE SPECIFICATIONS

8" Diameter Rail Wheels  
Transmission Guard  
Boom Protection  
Beacon Kit  
Dual Batteries w/ Disconnect  
LED Light Package



# 320P HL

## GLIDERAIL



### DIMENSIONS AND WEIGHTS (HL)

Operating Weight -	19,105 lbs (without attachments)
ISO 6016 Operating Mass -	18,133 lbs
ISO 6016 Gross Machinery Mass -	22,046 lbs
Operating Weight w/ Rail Gear -	~21,000 lbs

#### Dimensions - HL (Heavy Lift Option)

A. Ground Clearance, Minimum:	13 in
B. Overall Length, Transport:	24 ft 7 in
C. Width Over Tires:	7 ft 3 in
D. Height to Top of Cab:	9 ft 4 in
E. Length from Axle to Axle:	7 ft 2 in
F. Loading Height:	13 ft 9 in
G. Reach from Center of Swing Pivot:	21 ft 8 in
H. Reach from Center of Rear Axle:	25 ft 2 in
I. Digging Depth (SAE Maximum):	18 ft 4 in
J. Digging Depth	
2 ft Flat Bottom:	18 ft 2 in
8 ft Flat Bottom:	17 ft 6 in
K. Stabilizer Width, Transport:	7 ft 8 in
L. Stabilizer Spread:	11 ft 4 in
M. Stabilizer Width, Operating:	13 ft 3 in
N. Bucket Rotation:	190 degrees
O. Transport Height:	11 ft 6 in
Ground Clearance w/ Hi-Rail:	12 in
Width of Stabilizers in Stowed Position:	102 in

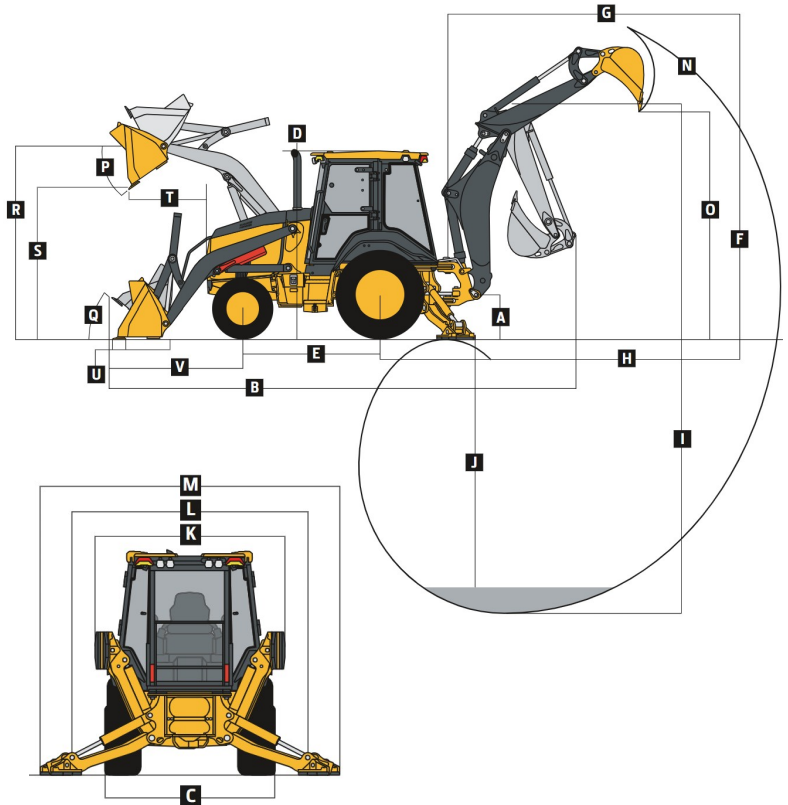

#### Lift Capacities with Quick-Coupler Forks

A. Maximum Height:	4,251 lbs
B. Maximum Reach:	6,649 lbs
C. At Ground Line:	8,521 lbs
D. Below Ground Line:	6.1 in

### REFILL CAPACITIES

Fuel Tank:	34.0 gal
Engine Oil:	13.7 qt
DEF Tank:	3.6 gal
Hydraulic System:	34.4 gal
Hydraulic Reservoir:	12.0 gal

